

METERS FURNISHED AND INSTALLED
BY RICHFIELD CITY

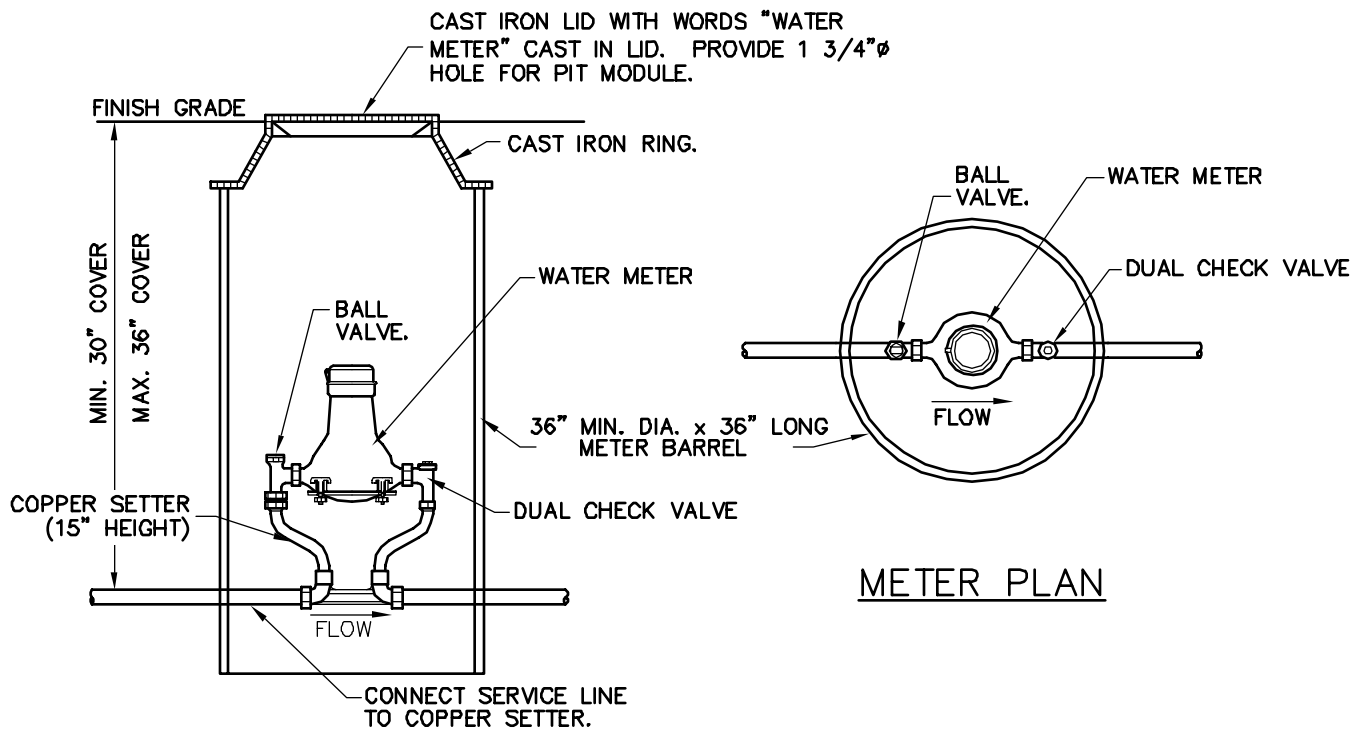

METER SECTION

METER PLAN

METER BOX DETAIL

(1 1/2" - 2" METERS)

- NOTES: 1. INSTALL TRACER WIRE WITH ALL SERVICE LINES.
2. WRAP TRACER WIRE AROUND COPPER SETTER.
3. USE CONCRETE BARREL WHEN METER IS LOCATED IN TRAFFIC AREA.

| REVISION DATE | |
|---------------|--------|
| 06/07/2007 | J.F.S. |
| | |
| | |

S-404

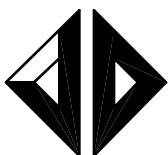

Jones & DeMille Engineering
1535 South 100 West - Richfield, Utah 84701
(435) 896-8266 Phone
(435) 896-8268 Fax
www.jonesanddemille.com

RICHFIELD CITY

WATER - CULINARY

| | | |
|------------------|--------------|------------------|
| SCALE: NONE | ENG.: T.M.J. | PROJ.#: 0501-144 |
| DATE: 01/24/2005 | DWG.BY: L.G. | DWG.NAME: water |